

# Spare-Parts List and Exploded View

(Ersatzteilliste-Explosionszeichnung)

## COOL-LINE-Tiefkühlschrank **TKU 710 GL-PLUS**

[Art. 451550300]

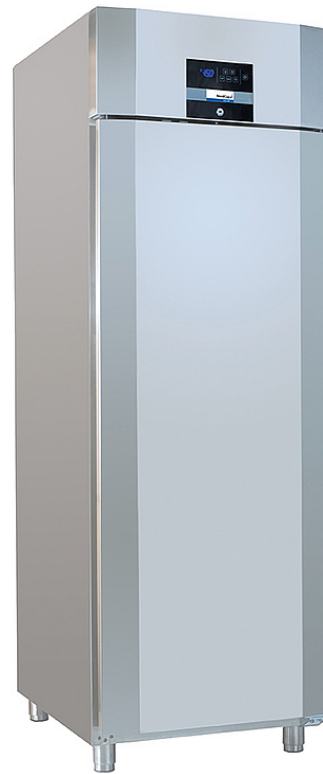

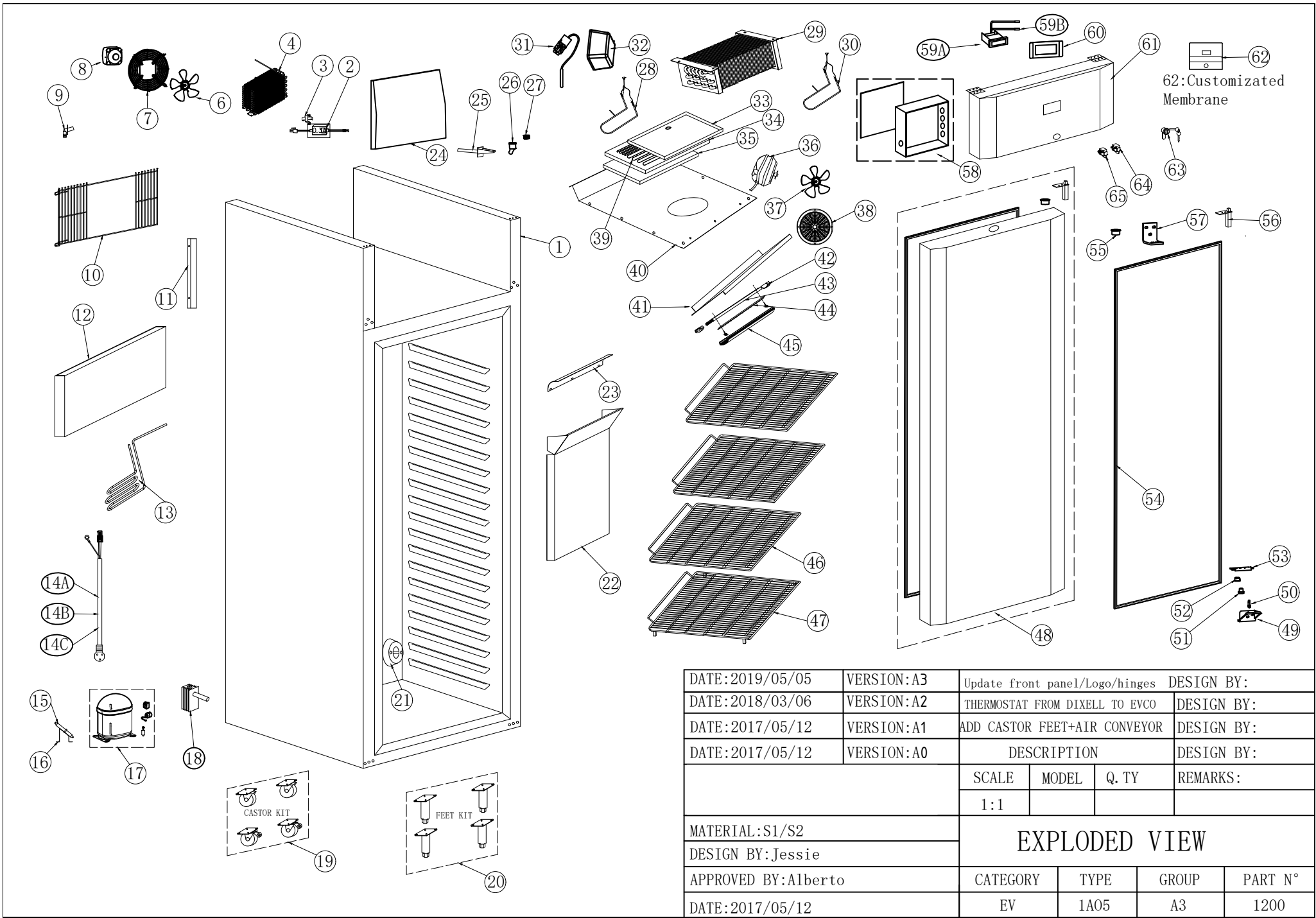

|                     |            |                                |       |            |         |
|---------------------|------------|--------------------------------|-------|------------|---------|
| DATE:2019/05/05     | VERSION:A3 | Update front panel/Logo/hinges |       | DESIGN BY: |         |
| DATE:2018/03/06     | VERSION:A2 | THERMOSTAT FROM DIXELL TO EVCO |       | DESIGN BY: |         |
| DATE:2017/05/12     | VERSION:A1 | ADD CASTOR FEET+AIR CONVEYOR   |       | DESIGN BY: |         |
| DATE:2017/05/12     | VERSION:A0 | DESCRIPTION                    |       | DESIGN BY: |         |
|                     |            | SCALE                          | MODEL | Q. TY      |         |
|                     |            | 1:1                            |       |            |         |
| MATERIAL:S1/S2      |            | <b>EXPLODED VIEW</b>           |       |            |         |
| DESIGN BY:Jessie    |            |                                |       |            |         |
| APPROVED BY:Alberto |            | CATEGORY                       | TYPE  | GROUP      | PART N° |
| DATE:2017/05/12     |            | EV                             | 1A05  | A3         | 1200    |

Item Description

**TKU 710 GL-PLUS**

BOM Number

1

Build Quantity

1

Fixed Cost

0

Remark

Unit pc

BOM Components

| Lev. 0     | Item Number  | Descr  | Quantity | u.m. | Spare Part |
|------------|--------------|--|----------|------|------------|
|            | EV1AO5A31200 | CN 7 - EXPLODED VIEW DRAWING (Ver.A3 - S12)                  | 1        | pc   | 1          |
| <b>1</b>   | S11AO50A0001 | CN 7/QN 7 - ASSEMBLED FOAMED BODY                            | 1        | pc   | 1          |
| <b>2</b>   | E26I30120080 | POWER SUPPLY MEANWELL APV-8-12 (12V -8W)                     | 1        | pc   | 1          |
| <b>3</b>   | Z01AF23A0002 | RNG 50/CR 7/CN 7/QR 7/QN 7/BBC 186 - LIGHT TRANSF. HOLDER    | 1        | pc   | 1          |
| <b>4</b>   | C01AO58A0001 | CN 7/QN 7/QN 14 - CONDENSER - (S12)                          | 1        | pc   | 1          |
| <b>5</b>   | S11AO08A0002 | CR 7/CN 7/QR 7/QN 7 - SAFETY COVER FOR CONDENSER             | 1        | pc   | 1          |
| <b>6</b>   | E181A2002801 | EBMPAPTS FAN BLADE D.200mm-28*; 300 M3/h                     | 1        | pc   | 1          |
| <b>7</b>   | E192A2003800 | FAN DIAGONAL GUARD GRILLE FOR BLADE D.200mm D.INT=212;W=38mm | 1        | pc   | 1          |
| <b>8</b>   | E17D1C120000 | ECM C12-10-02 ELCO FAN: 230V ;50/60Hz; CABLE LENGHT 300mm    | 1        | pc   | 1          |
| <b>9</b>   | P01AO00A0002 | CR/CN 7 - CR/CN 14 - EVAPORATOR TRAY DRAINAGE PIPE - (S12)   | 1        | pc   | 1          |
| <b>10</b>  | I01AO59A0001 | CN 7 - REAR ENGINE ROOM SAFETY GRID(For Conveyour)-S12       | 1        | pc   | 1          |
| <b>11</b>  | P01AO50A0004 | CN 7/QN 7 - REAR WIRING COVER - (S12)                        | 1        | pc   | 1          |
| <b>12</b>  | S21AO00A0003 | CR 7/CN 7 - REAR S/S WATER TRAY for CONDENSATION - (S12)     | 1        | pc   | 1          |
| <b>13</b>  | C01AO56A0003 | CN 7 - REAR EVAPORATION PIPE - (S12)                         | 1        | pc   | 1          |
| <b>14A</b> | E25EUB310300 | POWER CORD 3x1 mmq - EU PLUG - BLACK COLOR 3,0 Mt.           | 1        | pc   | 1          |
| <b>14B</b> | E25UKB310300 | POWER CORD 3x1 mmq - UK PLUG - BLACK COLOR 3,0 Mt.           | 1        | pc   | 1          |
| <b>14C</b> | E25AUB315300 | POWER CORD 3x1,5 mmq - AUSTRALIAN PLUG - BLACK COLOR 3.0 Mt. | 1        | pc   | 1          |
| <b>15</b>  | C01AE66A0001 | 400-600 ABS Ser./CR Salad./CR-CN 7/14 Ser-DRIER FILTER (S12) | 1        | pc   | 1          |
| <b>16</b>  | Z01AO03A0001 | CR/CN 7 - CR/CN 14 - SUPPORT FOR DRIER FILTER - (S12)        | 1        | pc   | 1          |
| <b>17</b>  | E27B2H2C0000 | NUT60CA - COMP.CUBIGEL R290-220-240V 50Hz-1/4 HP RSCR:       | 1        | pc   | 1          |
| <b>18</b>  | P01AO50A0002 | CN/QN 7-14 - AIR PRESSURE BALANCE VALVE - (S12)              | 1        | pc   | 1          |
| <b>19</b>  | KITCS1AO0A00 | CR 7/CR Counter - N.4 CASTOR KIT (N.2 NORMAL+N.2 WITH BRAKE) | 1        | pc   | 1          |
| <b>20</b>  | KITFT1AO0A00 | QR_GN Counter - FEET KIT(N.4 pc Min.140/Max160mm)            | 1        | pc   | 1          |
| <b>21</b>  | P01AO50A0003 | CN/QN 7-14 - INNER HOLDER FOR AIR PRESS.BALANCE VALVE- (S12) | 1        | pc   | 1          |
| <b>22</b>  | S21AO00A0005 | CR 7/CN 7/QR 7/QN 7 -INNER AIR CONVEYOUR EVA.FAN(Bigger)-ST2 | 1        | pc   | 1          |
| <b>23</b>  | S21AO00A0006 | CR 7/CN 7/QR 7/QN 7-INNER AIR CONVEYOUR EVA.FAN(Smaller)-ST2 | 1        | pc   | 1          |
| <b>24</b>  | S11AO50A0005 | CN 7/QN 7 - REAR AIR CONVEYOUR - (S12)                       | 1        | pc   | 1          |
| <b>25</b>  | P01AO00A0009 | CR/CN 7 - CR/CN 14 - CONNECT PIPE + HOLE COVER - (S12)       | 1        | pc   | 1          |
| <b>26</b>  | P01AO00A0008 | CR/CN 7 - CR/CN 14 - DRAIN PIPE - (S12)                      | 1        | pc   | 1          |
| <b>27</b>  | R01AO00A0007 | CR/CN 7 - CR/CN 14 - DRAIN PIPE PIPE SCREW CAP- (S12)        | 1        | pc   | 1          |

|     |               |  |   |    |   |
|-----|---------------|--|---|----|---|
| 28  | C01AO56A0001  | CN/QN 7-QN 14 -HEATING ELEM.N.1(130W-D.6,6mmq-N.2 Protector) | 1 | pc | 1 |
| 29  | C01AO57A0001  | CN 7/QN 7/QN 14 - EVAPORATOR (Anti-corrosion DL60501368-S12) | 1 | pc | 1 |
| 30  | C01AO56A0002  | CN/QN 7 - QN14 - HEAT.ELEM.N.2(200W-D.6,6mmq-N.2 Protector)  | 1 | pc | 1 |
| 31  | E45NC35000002 | CLIXON TCO (WY350A-C) - 250VAC/16A - 350°C - No Shaft        | 2 | pc | 1 |
| 32  | Z01CG13A0002  | QR/CR Series Cabinet - HOLDER FOR "TCO" CLIXON - (S12)       | 2 | pc | 1 |
| 33  | S21AO00A0010  | CR/CN 7 - QR/QN 7 - QN 14 - EVAPORATOR WATER TRAY-ST2        | 1 | pc | 1 |
| 34  | S21AO00A0011  | CR/CN 7 - QR/QN 7 - QN 14 - EVAPORATOR WATER TRAY BAFFLE-ST2 | 1 | pc | 1 |
| 35  | P11AO00A0012  | CR/CN 7 - QR/QN 7 - QN 14 - INSULATION FOAMING EVAP. TRAY    | 1 | pc | 1 |
| 36  | E17D1C120000  | ECM C12-10-02 ELCO FAN: 230V ;50/60Hz; CABLE LENGHT 300mm    | 1 | pc | 1 |
| 37  | E181A2002801  | EBMPAPTS FAN BLADE D.200mm-28*; 300 M3/h                     | 1 | pc | 1 |
| 38  | P01AO00A0013  | CR/CN 7 - CR/CN 14 - EVAPORATOR FAN SAFETY GRID - (S12)      | 1 | pc | 1 |
| 39  | E24200088500  | HEATING WIRE D.1x2,2mmq-L.8420mm-8W/Mt.                      | 1 | pc | 1 |
| 40  | S21AO00A0014  | CR 7/CN 7/QR 7/QN 7 - INNER EVAPORATOR BAFFLE                | 1 | pc | 1 |
| 41  | S21AO00A0015  | CR 7/CN 7/QR 7/QN 7 - EVAPORATOR COVER PLATE                 | 1 | pc | 1 |
| 42  | P01AO00A0016  | CR/CN 7 - CR/CN 14 - LIGHT TERMINAL STOPPER - (S12)          | 2 | pc | 1 |
| 43  | S21AO00A0017  | CR/CN 7 - CR/CN 14 - GROOVE FOR LED LIGHT - (S12)            | 1 | pc | 1 |
| 44  | E22AL0020045  | LED STRIPES LAMP-12VDC 1,92W-N.24 HIGH BRIGHT                | 1 | pc | 1 |
| 45  | P01AO00A0018  | CR/CN 7 - CR/CN 14 - COVER FOR LED LIGHT - (S12)             | 1 | pc | 1 |
| 46  | I01AO09A0001  | CR/CN 7 - GN2/1 UPPER/MIDDLE SHELF (650x534/Solid-S12)       | 3 | pc | 1 |
| 47  | I01AO09A0002  | CR/CN 7 - CR/CN 14 - BOTTOM SHELF(640x630mm/Solid door- S12) | 1 | pc | 1 |
| 48  | S11AO02A0001  | CR/CN 7-CR/CN 14-DOOR SET(Inc. Gasket+Self Closing+Pin+Cap)  | 1 | pc | 1 |
| 49  | A01AO02A0004  | CR /CN 7 - CR/CN 14 - BOTTOM HINGE (Model SOLID DOOR)-S12    | 1 | pc | 1 |
| 50  | Z01AE62A0005  | RC/RN 400/600-CR/CN 7-14-PIVOT BOTTOM/UPPER RIGHT HINGE-(S12 | 1 | pc | 1 |
| 51  | Z01AE62A0010  | RC/RN 400/600-CR/CN 7-14 - BOTTOM TURN AXIS REINFORC.-(S12)  | 1 | pc | 1 |
| 52  | N01AE62A0009  | RC/RN 400/600-CR/CN 7-14 - NYLON UP SLIP COVER (White-S12)   | 1 | pc | 1 |
| 53  | Z01AE62A0012  | RC/RN 400/600-CR/CN 7-14 - DOWN TURN AXIS - (S12)            | 1 | pc | 1 |
| 54  | R01AO02A0002  | CR/CN 7 - CR/CN14 - SOLID DOOR GASKET (3 Room-S12)           | 1 | pc | 1 |
| 55  | N01AO02A0006  | CR/CN 7 - CR/CN 14 - INSERT FOR SOLID DOOR LOCK-(S12)        | 2 | pc | 1 |
| 56  | Z01AE62A0006  | RC/RN 400/600 - CR/CN 7-CR/CN 14-SELF CLOSING SPRING-(S12)   | 1 | pc | 1 |
| 57  | A01AO02A0003  | CR /CN 7 - CR/CN 14 - UPPER HINGE - (S12)                    | 1 | pc | 1 |
| 58  | P01AO01A0005  | CR/CN 7 - CR/CN 14 - BOX + COVER FOR THERMOSTAT - (S12)      | 1 | pc | 1 |
| 59A | E20A113F5E01  | EV3B23N7VXBB01 EVCO THERMOSTAT (RWE) FREEZER                 | 1 | pc | 1 |
| 59B | E212AA030B01  | NTC PROBE - CABLE 3000 mm BLACK Color (Temperature)          | 2 | pc | 1 |
| 60  | S11AO01A0002  | CR/CN 7-14 - FIXED BRACKET FOR EVCO THERMOSTAT               | 1 | pc | 1 |
| 61  | S11AO01A0010  | CR/CN 7 - FRONT PANEL (Evco-Incl.hinges - NO Main hole-S12)  | 1 | pc | 1 |
| 62  | P01AO01A000Y  | CR/CN 7 - CUSTOMIZATED Sticker(SOLID Door/No Main/WITH LOCK) | 1 | pc | 1 |
| 63  | Z01AO01A0006  | CR/CN 7-14 - QR/QN 7/14 - SOLID DOOR LOCK+N.2 Keys - (S12)   | 1 | pc | 1 |
| 64  | E2309WH00001  | HF-D02-1A-1 DOOR SWITCH (2P) 250VAC-4A; CONTACT NC           | 1 | pc | 1 |
| 65  | E2309WH00003  | HF-D02-1A-3 DOOR SWITCH (3P) 250VAC-4A; CONTACT NO/NC        | 1 | pc | 1 |