

Ersatzteilliste-Explosionszeichnung

Gewerbekühlschrank KU 1950 G-SD

[Art. 435700401]

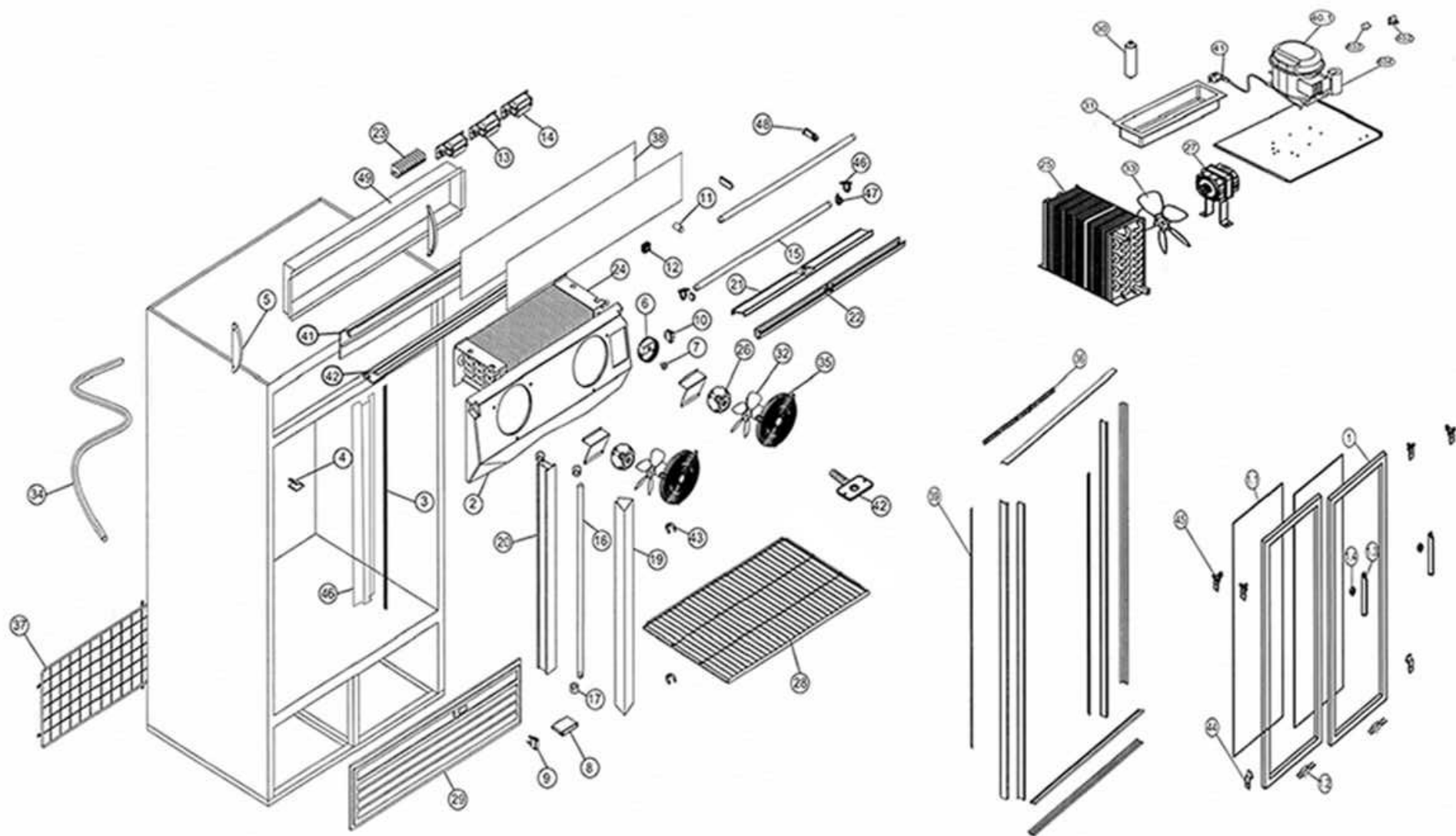



Date: 26-05-2020

POS.	REF.NO.	ITEM	Unit
00003	2117641023	EVAPORATOR FAN MOTOR 1300 RPM	STK
00004	2122601045	EVAPORATOR FAN FRAME	STK
00005	2122601046	FINGER GUARD	STK
00006	3414610210	FAN BLADE Ø200 5 WINGS	STK
00007	2117641024	EVAPORATOR FAN GROUP	STK
00012	2117641028	LED POWER SUPPLY 12VDC 60W	STK
00014	2114618019	CANOPY END COVER LEFT	STK
00015	2114618018	CANOPY END COVER RIGHT	STK
00018	2117641032	COVER FOR INTERNAL TUBES	STK
00022	2117641035	THERMOSTAT BRACKET	STK
00024	2117641036	THERMOSTAT CAREL PZPU	STK
00026	2112700083	MIDDLE SUPPORT	STK
00027	2112700081	ROLLER	STK
00028	1014610190	ADJUSTABLE SCREW FOOT	STK
00029	2115200060	CLIP FOR SHELF	STK
00030	1014680127	RAILS FOR SHELVES	STK
00032	2112700012	DOOR BRACKET FOR ROLLERS LEFT	STK
00036	2117641039	DOOR STOPPER	STK
00038	2116000077	SHAFT FOR ROLLER	STK
00039	2116000069	DOOR ROLLER	STK
00040	2116000074	BEARING FOR SLIDING DOORS	STK
00041	2116000075	CIRCLIP FOR ROLLERS	STK
00042	2116000078	DOOR BRACKET FOR ROLLERS RIGHT	STK
00045	2117641041	DOOR SEALING	STK
00046	2117641042	LED BASE PROFILE	STK
00047	2117641043	LED STRIP 1250 MM 2700K	STK
00047	1016208101	1200 MM LED STRIP 6500K 7LM	STK
00048	1920100022	END CAP LED LIGHT	STK
00052	3914620002	DRIP TRAY	STK
00053	2117641044	CONDENSER	STK
00054	2117641045	CONDENSER CLIP	STK
00055	1713700071	FAN MOTOR DIV. USE/CONDENSER	STK
00056	1713700207	FAN BLADE 25 CM (CONDENSER)	STK
00057	4802500021	FAN MOTOR BRACKET	STK
00059	3511010013	FILTER DRIER	STK
00061	7110000397	PROBE NTC DIXELL/CAREL 10 Kohm	STK