

ID	Service parts	S-RS	Description
A-01	6.014.012.017	S	Key
A-02	6.014.004.052	S	Lock incl. key/spring
A-03	6.329.529.001	S	Rotor fan
A-04	6.329.530.001	S	Grid fan
A-05	6.329.060.001	DT	Foot
A-06	6.329.411.001	S	Drip-tray
A-07	6.229.116.001	S	Float drip-tray
A-08	6.329.233.001	S	Drip-tray plate
A-09	6.329.409.001	S	Hinge
A-10	6.329.410.001	S	Hinge pin
A-11	6.229.974.001	S	Push button
A-12	6.229.975.001	S	Push button
A-13	6.229.980.001	S	Push button
A-14	6.229.979.001	S	Switch hot water 1/2
A-15	6.229.976.001	S	Switch hot water
A-16	6.229.977.001	S	Program switch
A-17	6.229.978.001	S	Switch
A-18	6.214.105.001	RS	Switch (impulse)
A-19	6.329.208.001	DT	Cover
A-20	6.229.644.001	S	Inlet flatcable
A-21	6.329.408.001	DT	No drip plate
A-22	6.000.229.205	S	Drip plate (assy)

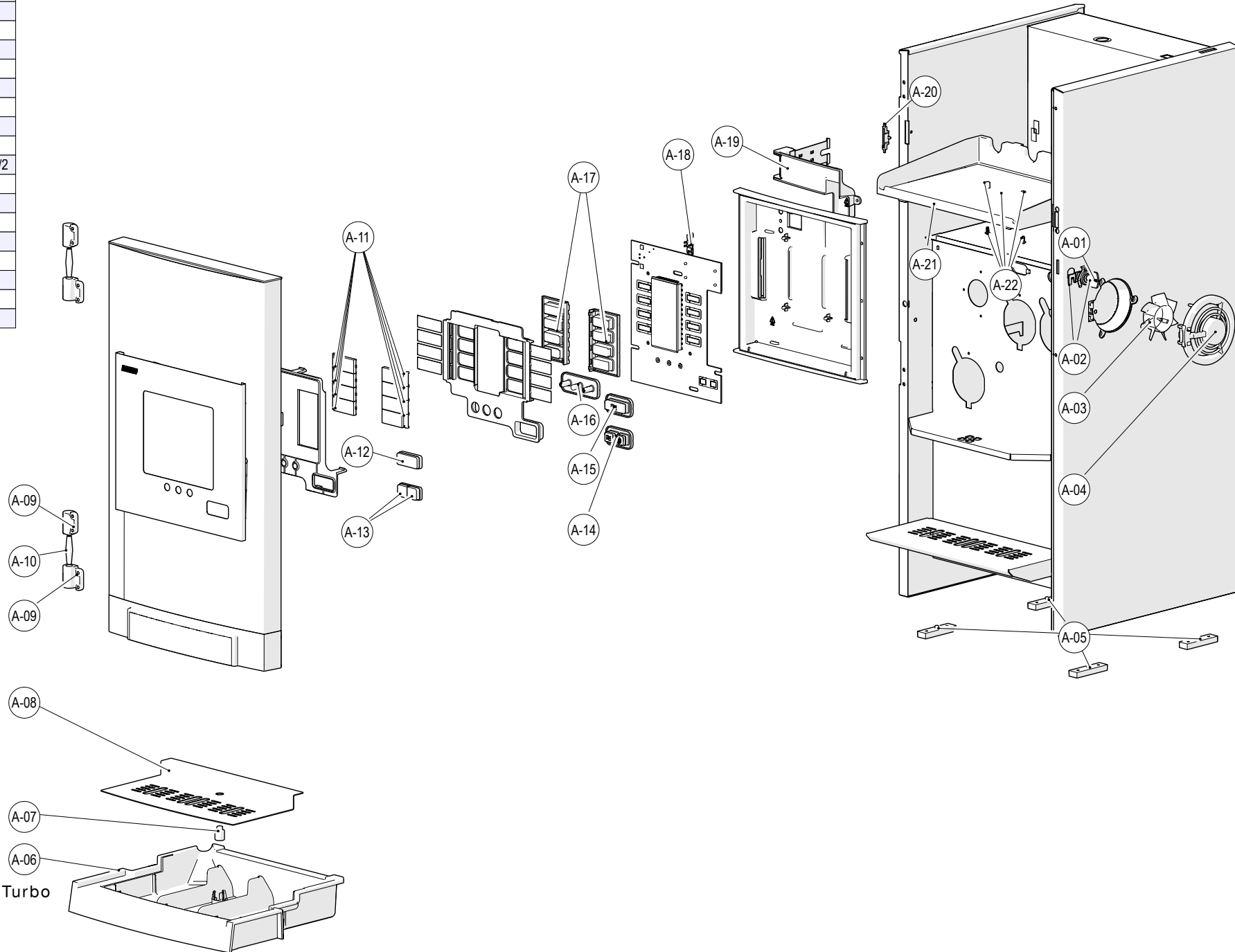

ID	Service parts	S-RS	Description
B-01	6.xxx.xxx.xxx	RS	Keyboard
B-02	6.017.006.005	S	Fan
B-03	6.004.001.078	RS	Techno switch
B-04	6.329.485.001	S	Counterpart safety switch
B-05	6.004.003.043	RS	Safety switch
B-06	6.005.012.008	S	Fuse holder
B-07	6.005.011.016	S	Fuse 4A (10 pcs)
B-08	6.030.074.006	S	Drive shaft
B-09	6.030.070.017	RS	Canister motor
B-10	6.329.419.000	RS	Mainboard
B-11	6.329.428.001	S	Foil
B-12	6.000.229.189	RS	Motor ventilator
B-13	6.004.002.093	RS	Relay
B-14	6.004.011.099	RS	Switching power supply
B-15	6.002.019.160	S	Wire clamp
B-16	6.006.001.059	S	Cord inlet M16x1.5

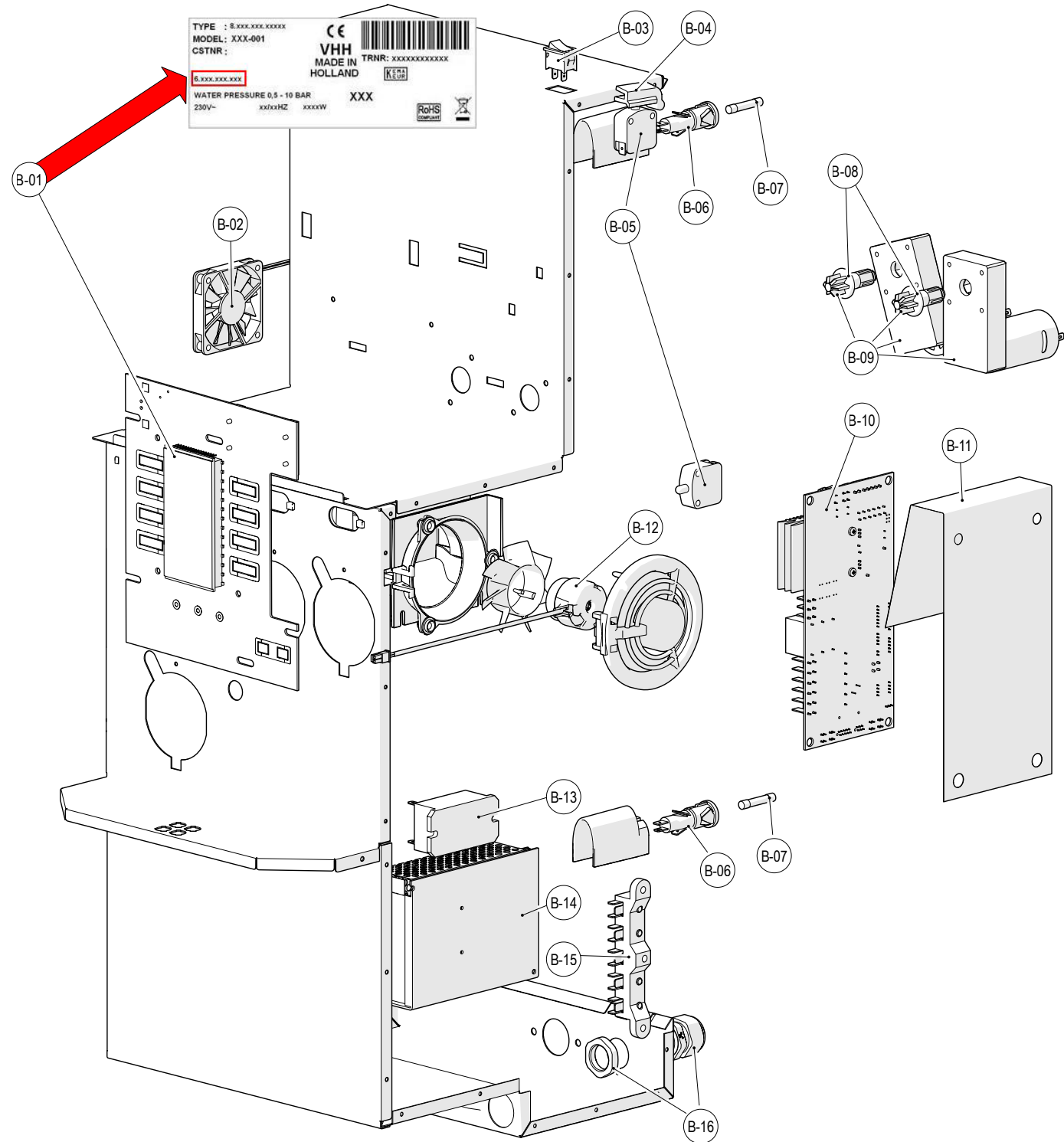

ID	Service parts	S-RS	Description
C-01	6.229.273.001	S	Lid 65mm
C-02	6.329.477.001	S	Drive shaft
C-03	6.329.478.001	S	Wiper
C-04	6.329.486.001	S	Axle
C-05	6.329.476.001	S	Canister casing
C-06	6.000.229.219	S	Axle
C-07	6.329.479.001	S	Seal
C-08	6.329.474.001	S	Canister bottom
C-09	6.329.087.000	S	Outlet canister compl (centr)

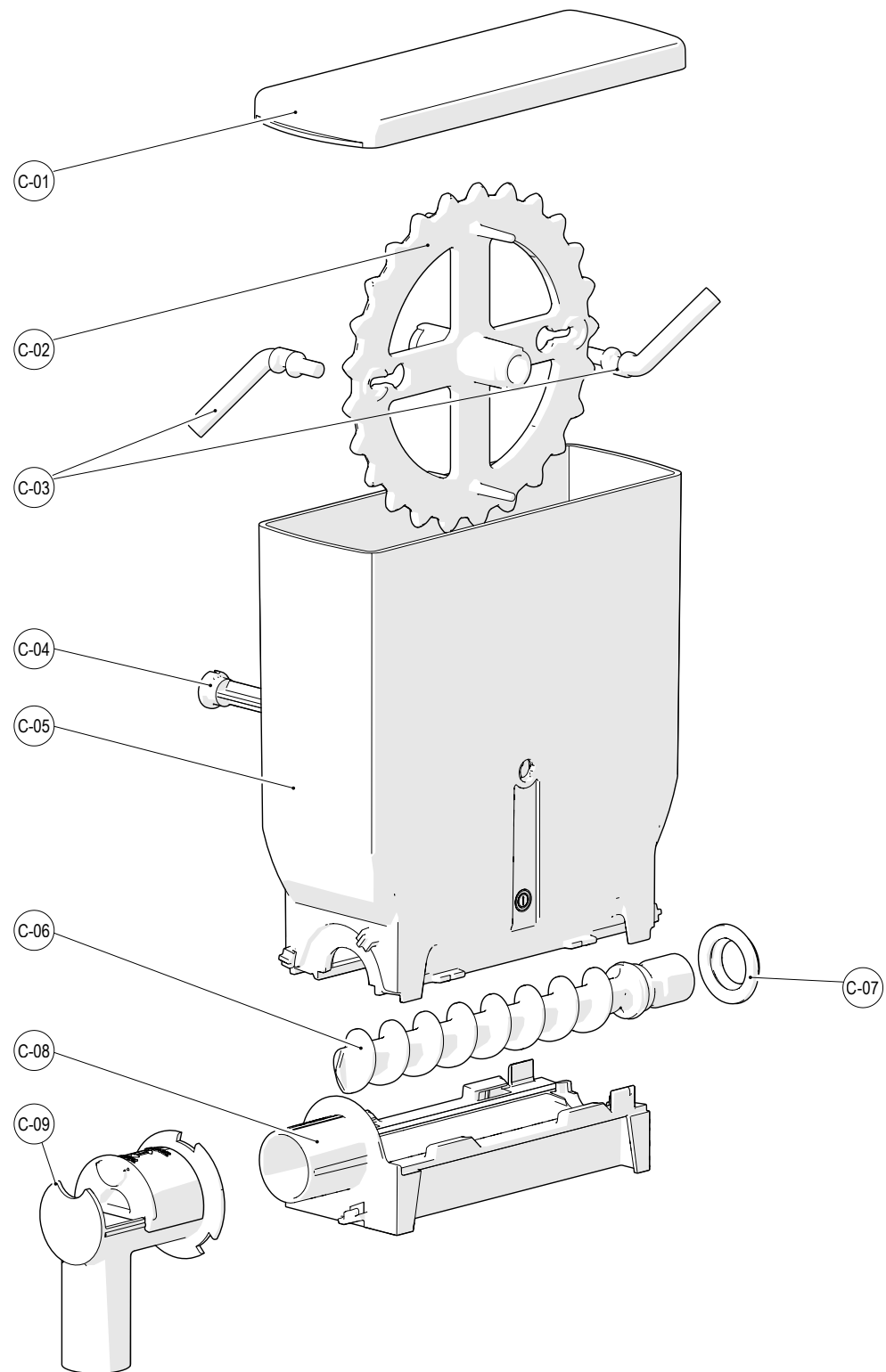

ID	Service parts	S-RS	Description
D-01	6.229.808.001	S	Condense reservoir
D-02	6.329.490.001	S	Mixing beaker
D-03	6.011.001.073	S	O-ring
D-04	6.229.809.001	S	Fastening ring
D-05	6.229.803.001	S	Whipper disk 6 mm
D-06	6.229.806.001	S	Rubber seal mixer
D-07	6.030.071.020	S	Rubber seal mixer
D-08	6.229.807.001	S	Holder rubber seal
D-09	6.229.810.001	S	Plate mixer moter
D-10	6.011.001.094	RS	O-ring 13x2
D-11	6.019.033.004	RS	Mixer motor
D-12	6.000.229.085	RS	Mixer motor NSF (assy)
D-13	6.329.348.001	S	Protection lid mix unit
D-14	6.013.005.013	S	Non return valve
D-15	6.000.229.263	S	Protection lid mix unit (assy)
D-16	6.023.004.037	S	Pump housing
D-17	6.000.229.186	S	Pump (assy)

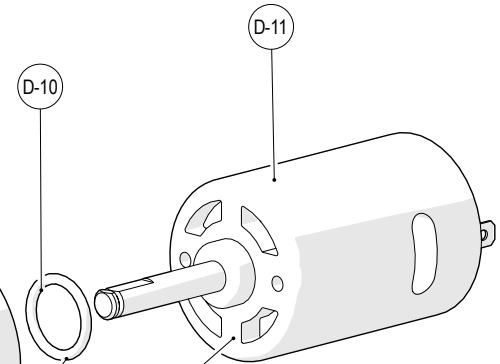
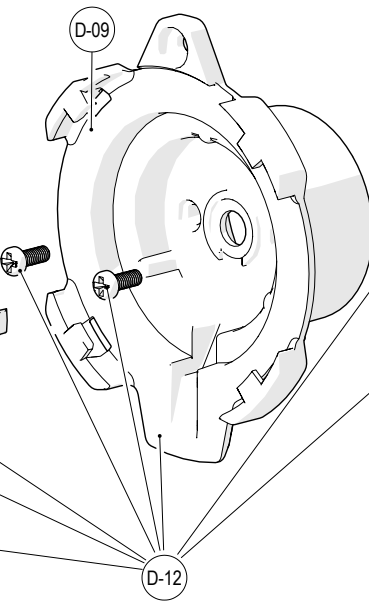
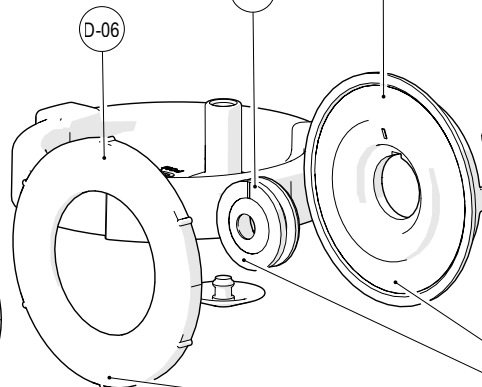
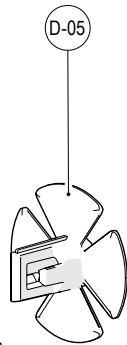
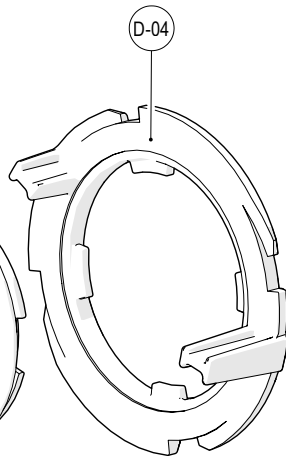
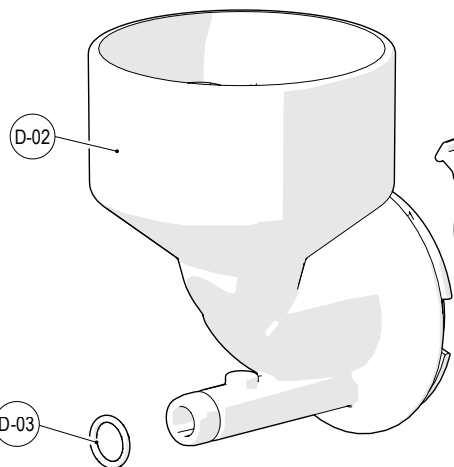
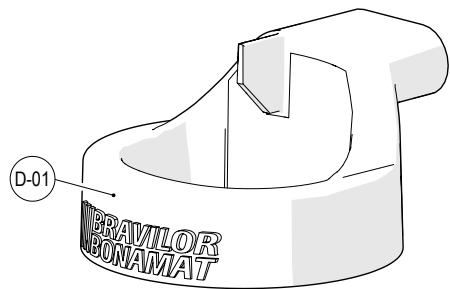
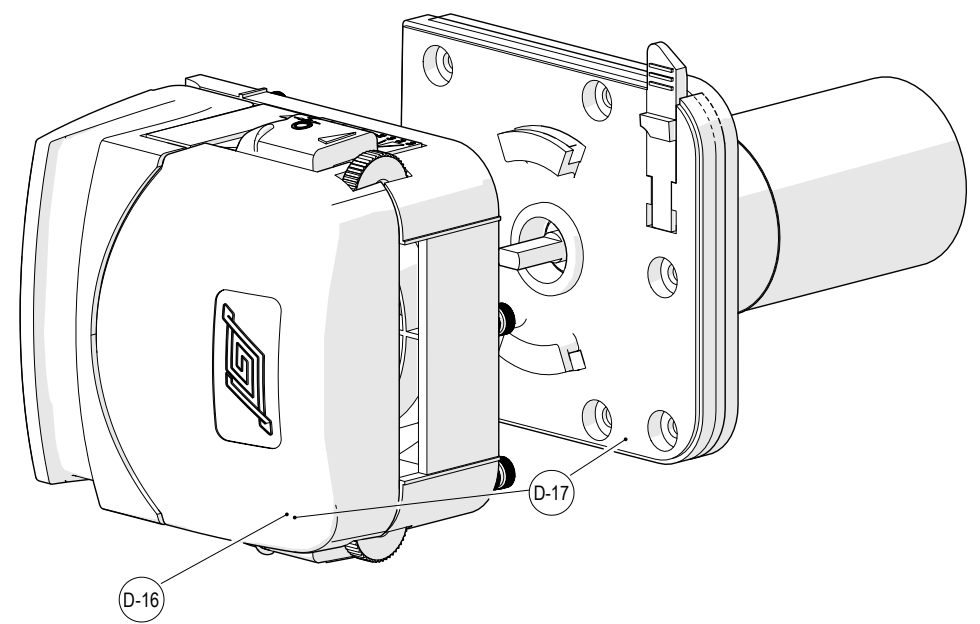
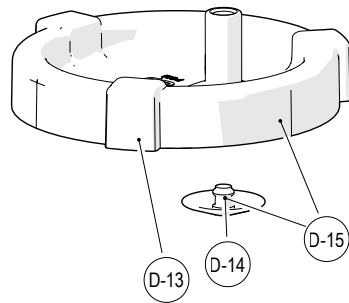

ID	Service parts	S-RS	Description	mm
E-01	6.000.205.111	S	Connection hose	
E-02	6.016.001.112	RS	Magnetic valve 3.8 L/min	
E-03	6.001.079.003	S	Tube clamp 15,6 mm	
E-04	6.019.033.014	S	Silicone tube 15,5 x 9,5	820
E-05	6.019.033.013	S	Silicone tube 17,5 x 11,5	720
E-06	6.329.470.001	S	Evacuation hose 12.0x3.0	
E-07	6.329.539.001	DT	Plug	
E-08	6.229.774.001	S	Tube	350
E-09	6.019.033.009	S	Silicone tube 7 x 4	220
E-10	6.019.033.004	S	Silicone tube 7,5 x 2	540
E-11	6.019.033.004	S	Silicone tube 7,5 x 2	460
E-12	6.019.033.004	S	Silicone tube 7,5 x 2	350
E-13	6.019.033.004	S	Silicone tube 7,5 x 2	350
E-14	6.019.033.004	S	Silicone tube 7,5 x 2	575
E-15	6.329.491.001	DT	Water inlet	
E-16	6.011.001.167	S	O-ring	
E-17a	6.028.016.001	S	Connector 1910L	
E-17b	6.028.016.003	S	QSS connector (3/16 in)	
E-18	6.019.033.026	S	Silicon tube 6.5x1.6	600
E-19	6.329.569.001	S	Hose	
E-20	6.329.570.001	S	Hose 7.5x2 + curve 81°	152
E-21	6.329.570.001	S	Hose 7.5x2 + curve 81°	180
E-22	6.231.177.003	S	Coffee outlet	
E-23	6.019.033.017	S	Silicone tube 18x24	80
E-24	6.329.522.001	DT	Fill tube	
E-25	6.329.528.000	DT	Descaling plug	
E-26	6.229.248.001	S	Overflow hose	
E-27	6.229.760.001	S	Nipple	
E-28	6.014.017.007	S	Spring	
E-29	6.001.079.013	S	Tube clamp 20.6 mm	

7.270.511.101 Parts set B.I.B.

- Silicone tube 6.5x1.6 naturel, l=1000mm
- Tube shut-off clamp 30 mm
- BIB connector 3/16

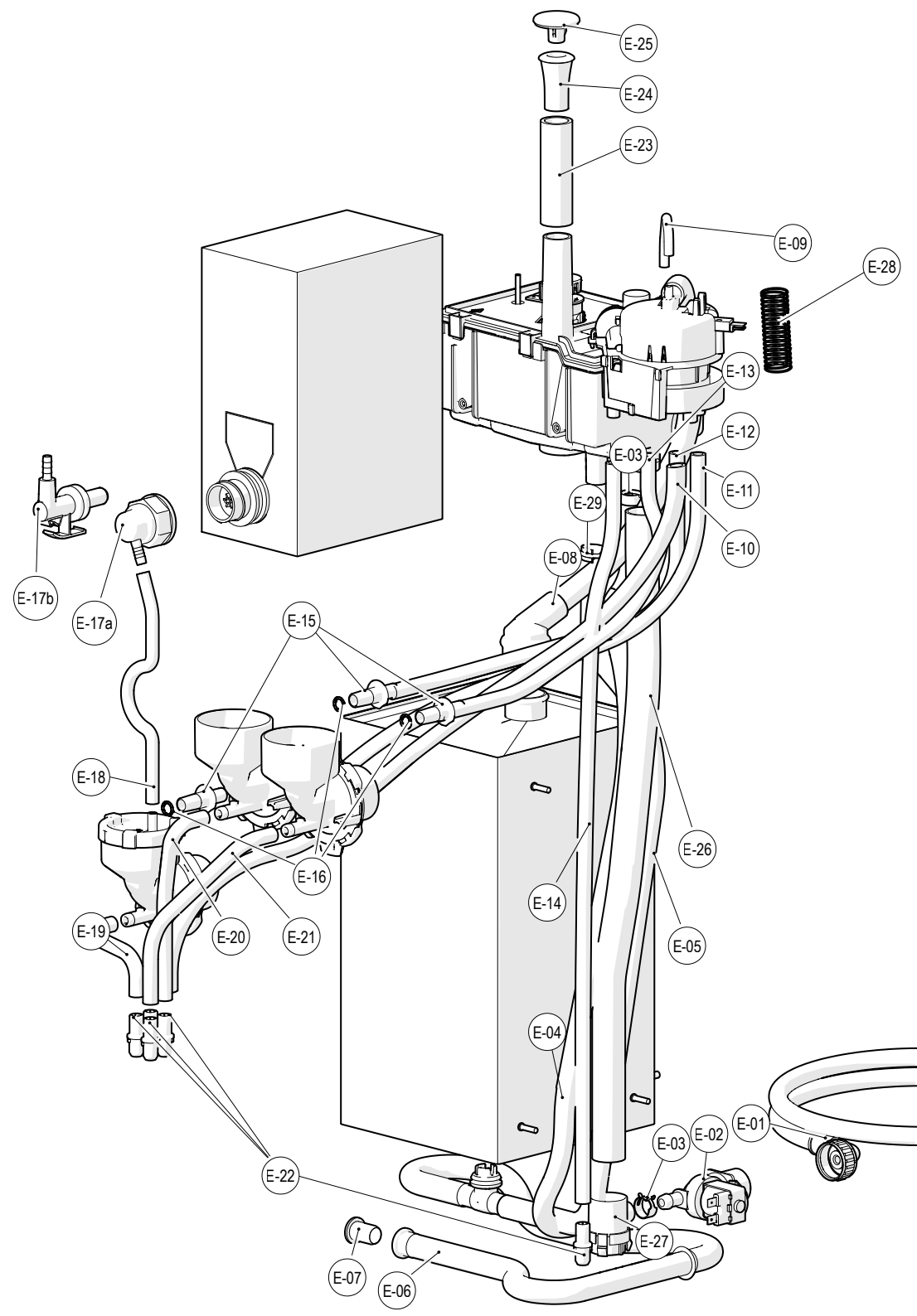
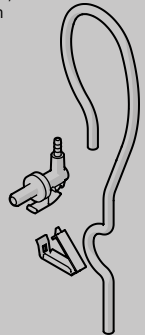

ID	Service parts	S-RS	Description
F-01	6.229.829.001	S	Nipple
F-02	6.000.229.165	S	Lid
F-03	6.229.643.001	S	Float
F-04	6.000.229.199	RS	Pump motor (assy)
F-05	6.229.745.001	S	Pumpfloat tank

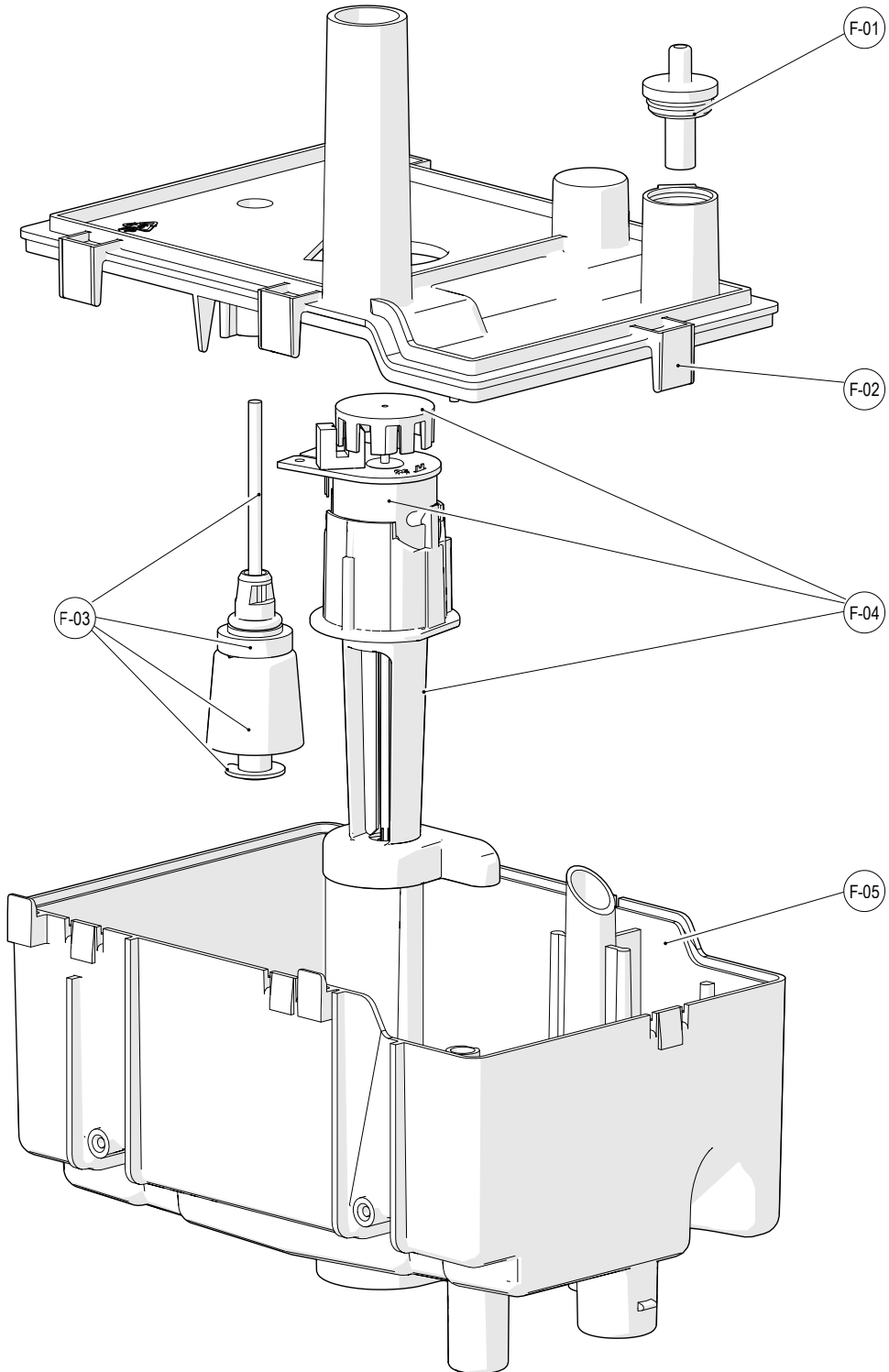

ID	Service parts	S-RS	Description
G-01	6.229.681.000	S	Flat cable lightsensor
G-02	6.004.026.001	RS	Light sensor
G-03	6.231.121.001	S	Lid water selector
G-04	6.000.231.022	RS	Motor water selector (assy)
G-05	6.231.572.001	S	Water rotation disk
G-06	6.231.130.001	S	Outlets (4) water selector
G-07	6.329.521.001	S	Drip-tray

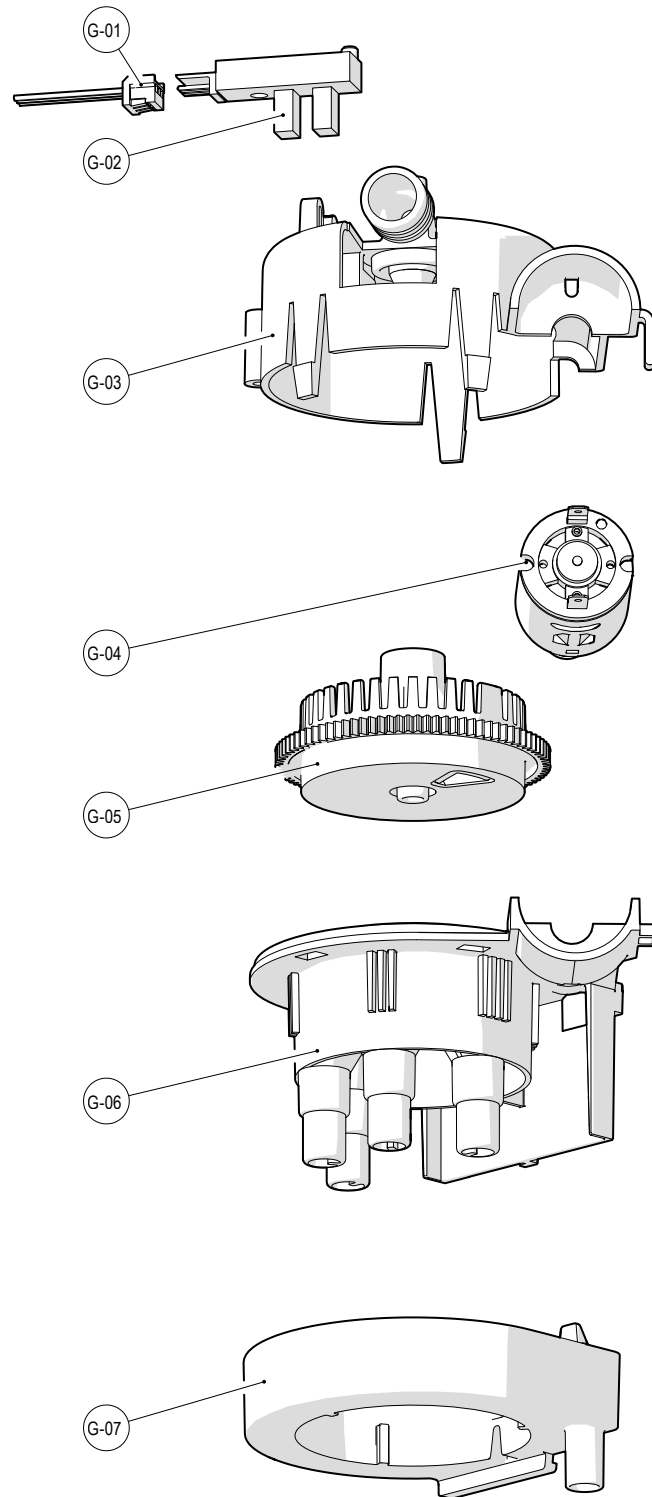

ID	Service parts	S-RS	Description
H-01	6.016.008.064	RS	High temperature safety switch
H-02	6.231.191.001	S	Seal
H-03	6.231.551.001	S	Supply boiler
H-04	6.236.188.000	RS	Temperature sensor (assy)
H-05	6.006.010.082	S	Wire clip Ø 12,7
H-06	6.329.370.010	DT	Insulation part 1
H-07	6.329.370.012	DT	Insulation part 3
H-08	6.329.370.011	DT	Insulation part 2
H-09	6.011.001.155	S	O-ring
H-10	6.236.321.000	RS	Element 240V 2180W complete
H-11	6.233.107.000	RS	Element 230V 1450W complete

